

Serenity

Option 1 including EPDM rubber flat roof 3.5m x 3.5m

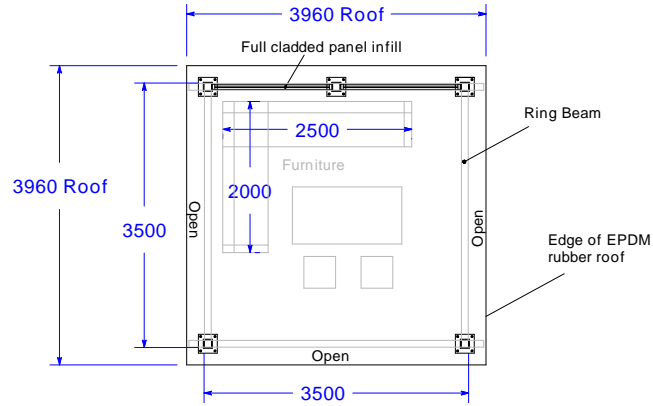

Plan View

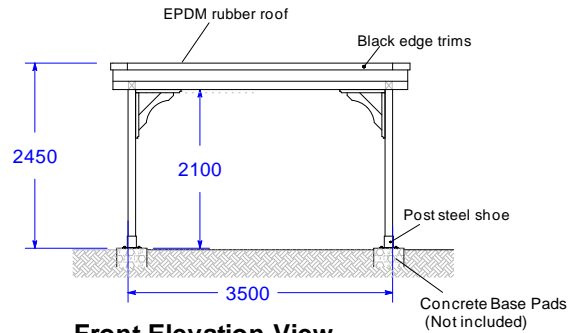

Front Elevation View

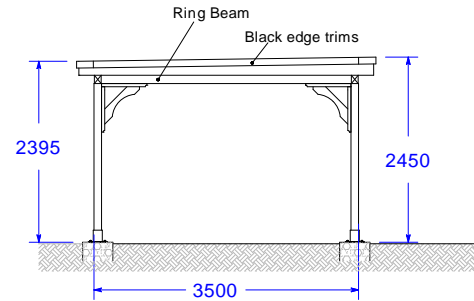

Left Elevation View

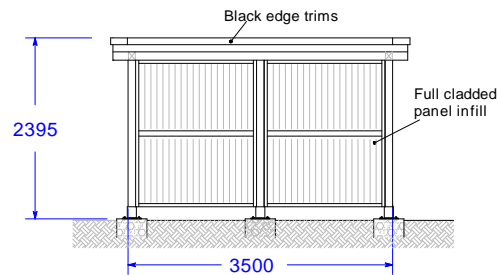

Back Elevation View

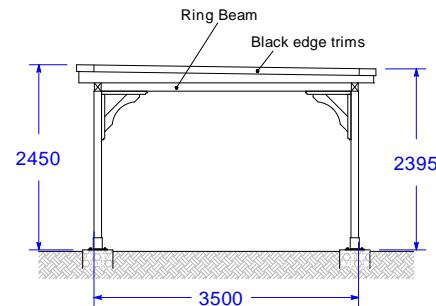

Right Elevation View

The LivingWell
Collection by Crown
Pavilions



CROWN PAVILIONS
HAMPTON COURT

Ord No: A		T.G.	
Version	2003	2003	
Drawing Date	Checked Date	Approved Date	
Client			
Project Serenity			
Drawing Title			
Crown Pavilions Architectural Designs and Development/Consultants			
Office	Scale		
6b Lys Mill Farm Howe Road Watlington Oxfordshire OX46 5EP Tel: 01491612820 Fax: 01491614747	1:100@A4		
Purpose of Issue			
Drawing No. 300320-1v1			